



# Kalyn Siebert Equipment Manual



**Sliding Axle Trailer**

**ENGINEERED TO PERFORM. BUILT TO LAST.**



## INDEX

- A. Introduction
  - A.1 Purpose of Document
  
- B. Your Trailer Information
  - B.1 Specification of the Build
  
- C. Important Safety Messages
  - C.1 Safety Messages
  
- D. Equipment Operation
  - D.1 Equipment Introduction
  - D.2 Connecting Equipment to Prime Mover
  - D.3 Disconnecting from Prime Mover
  - D.4 Understanding Equipment controls
  - D.5 Equipment Operations
  - D.6 Accessories
  
- E. Preventative Maintenance
  - E.1 Lubrication
  - E.2 Tires & Wheels
  - E.3 Brakes
  - E.4 Torque Requirements
  - E.5 Axle alignment
  - E.6 Preventative Maintenance Schedule
  
- F. Parts of your Equipment
  - F.1 Ordering Parts and Accessory Equipment
  
- G. Warranty
  - G.1 Limited Warranty Agreement
  - G.2 Copy of Equipment registration form

## A. INTRODUCTION

Thank you for trusting and purchasing Kalyn Siebert Equipment. We at Kalyn Siebert take pride in the products we manufacture. We trust you will be well satisfied with your purchase.

Kalyn Siebert has a long heritage of serving the customers in the trailer industry from 1961. We are recognized as the premier engineering and manufacturing company of the most diverse line of heavy-duty trailers and related products and services for the military, energy, construction, and transportation markets. Through strong relationships, building the highest quality products, and delivering the best customer service we stand tall among the industry. We welcome you to the Kalyn Siebert Family.

### A.1. PURPOSE OF DOCUMENT

The purpose of this manual is intended to help ensure the safe and efficient operation of your Kalyn Siebert equipment.



Incorrect operation, maintenance or repair, this equipment can cause severe injury, death and or property damage. Those who use, operate, maintain and repair the equipment should be trained in its proper use, operation, maintenance and repair, warned of its dangers, and should read this entire manual before attempting to use, operate, maintain, set up, adjust, service or repair the equipment. Recommended operating practices furnished in this manual are general industrial practices.



Keep this manual for future reference.

## B. Your Trailer Information

**Family:** Kalyn Siebert – Hydraulic Controlled Sliding Axle Trailer



**Model:** To find the information of your equipment, please refer to the specification provided during the initial sale.

**VIN:** Vehicle Identification Number could be found on the data plate towards the front of the trailer or roadside on models. The last 4 digits of the VIN will be punched on the front of the deck.

For all inquiries, reference the equipment using the model and VIN number of the unit. This is found on the manufacturer’s data plate attached to the equipment.

|   |     |    |          |               |                 |  |       |
|---|-----|----|----------|---------------|-----------------|--|-------|
| THIS VEHICLE CONFORMS TO ALL APPLICABLE (U.S.) FEDERAL MOTOR VEHICLE SAFETY STANDARDS<br>IN EFFECT ON DATE OF MANUFACTURE SHOWN BELOW |     |    |          |               |                 |  |       |
| DATE OF MFG.  |     |    |          | V.I.N.        |                 |  |       |
| MODEL   |     |    |          | TYPE          |                 |  |       |
| FRAME RATING  |     |    |          | IN            | FEET            |  |       |
| TIRES   |     |    |          | PLY           | RIMS            |  |       |
| RATING AT   | MPH | AT | PRESSURE | PSI COLD DUAL | NUMBER OF AXLES |  |       |
| GVWR  |     |    |          | GAWR          | ALL AXLES       |  |       |
| RATING AT   | KPH | AT | PRESSURE | KPA COLD DUAL | NUMBER OF AXLES |  |       |
| GVWR  | KG  |    |          | GAWR          | KG ALL AXLES    |  |       |
| CAUTION CUSTOMER BEARS ALL RESPONSIBILITY FOR EXCEEDING<br>GVWR AND OR GAWR DESCRIBED ABOVE.  |     |    |          |               |                 |  | L0089 |

## C. IMPORTANT SAFETY MESSAGES

All work equipment has the potential to cause problems in the workplace. If we fail to manage the risks associated with the use of work equipment, we could be putting the person using that piece of equipment and others at risk. We can mitigate the risk to personal and property by selecting suitable equipment, using it properly, following manufactures recommendations and training people to use the equipment correctly. However, if not used appropriately, they can pose serious risks. Please read the section before operating Kalyn Siebert equipment.

### C.1. SAFETY MESSAGE DEFINITIONS

The following are the safety alert symbols used throughout this manual. ‘Danger’ and ‘Warning’ signs accompany instances of resulting condition could be serious damage, serious injury or death to operator and/or equipment.



‘Caution’ and ‘Notice’ signs accompany of instances of resulting condition could be minor/moderate damage to equipment/ property and/or minor/ moderate injury to personal.



When you see these symbols, carefully read the messages that follow and be alert to the possibility of environmental and/or property damage, personal injury or death to yourself or others.

### C.2. SAFETY MESSAGES



Do not alter or modify any of the equipment or components provided with the equipment / trailer. Use of non-Kalyn Siebert parts or non-OEM component parts may cause serious injury or death.



Overloading will aggravate the conditions that cause tip-overs. Kalyn Siebert trailers are designed to carry and handle legal loads. Damage to personal or equipment could be caused due to overloading. Do not exceed the GVWR & comply with local laws.



Proper operation of the Kalyn Siebert equipment / trailer’s primary brake system is essential for safe operation of the

vehicle. A functional system check is necessary each time the equipment is put into service.



Like any other vehicle, Kalyn Siebert trailers can tip or slide out of control if turns are negotiated at too high a speed or when making violent maneuvers such as abrupt lane changes. Such unsafe and improper operation may cause serious personal injury, including death, to the operator, handlers, and bystanders.



Never set a loaded trailer on landing legs that are not intended for that purpose.



Inspection of equipment, safety devices, and working areas must be performed before each trip to ensure personal and operational safety and to correct potential or actual hazards.



Decals are posted on the equipment to alert the operator or to give important safety instructions. Decals should be replaced if they are torn, damaged or if they become illegible.



The trailer should not be operated if any of the following conditions exist:

- Damage to lighting fixtures, wiring, electrical conduits, or inoperative lights
- Leaking or malfunctioning equipment
- Damage to the tractor or trailer, including but not limited to interior damage
- Inoperative brake systems (primary or parking)

Failure to correct or repair any of these conditions may result in extensive property damage and/or serious personal injury, including death.



If the Kalyn Siebert trailer is uncoupled in soft surface like mud, snow or sand, use extra shoring to provide an adequate base for the landing gear support pads.



To avoid damage to bearings and potential wheel end failure, use only compatible lubrication products recommended. Use the right hydraulic oil for the hydraulic system recommended. Periodically lubricate all the points of lubrication based on the chart in the maintenance section based on the frequency and type of lubricant recommended. For the recommended lubrication products for different application on the equipment refer the maintenance section.



After the first 50-100 miles, re-torque all wheel nuts to 450-500 ft.-lbs. To avoid loose or malfunctioning wheels, maintain torque levels at the proper values through planned periodic checks. Tighten all bolts and nuts every 5000 miles.

## D. Equipment Operation

### D.1. Equipment Introduction

General nomenclature used to describe the parts of a sliding axle trailer are shown below. Along with these terms curb side (CS), road side (RS) and Rear bumper will be used.

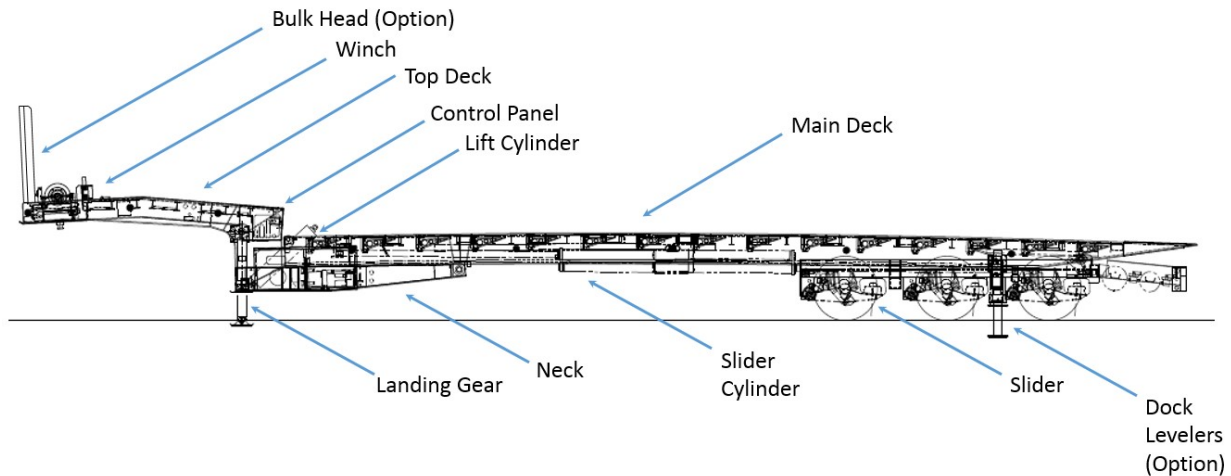

Failure to follow the proper procedure may result in injury or death to equipment or personal

### D.2. Connecting to Prime Mover

This segment describes the method to connect a prime mover / tractor to the trailer.

- a) Back up tractor to the trailer and stop just as the 5th wheel touches the trailer and apply the parking brakes
- b) Get out of cab to check that the height of the 5th wheel matches that of the trailer. If not use the landing gear to position the trailer height

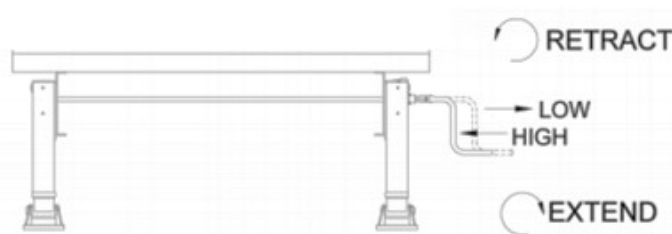

Landing Gear – Front View

- c) Confirm that the handle is out and the 5th wheel locking dogs are locked
- d) Check for the 5th wheel handle to be in position when 5th wheel jaws are in the locked position & there is no light or space between the 5th wheel and the trailer. Confirm 5th wheel jaws are locked behind the trailer king pin. Use a flashlight if necessary
- e) Wind up the trailer landing gear an inch



- f) Conduct a tug test to confirm that the 5th wheel is locked to the king pin. If it does not lock back up tractor again to give it another chance to lock. If this does not happen after multiple tries inspect the 5<sup>th</sup> wheel mechanism on the tractor
- g) Finish winding up the landing gear to travel position – all the way up
- h) Attach the glad hands for air lines & electrical receptacle (& hydraulic if needed)

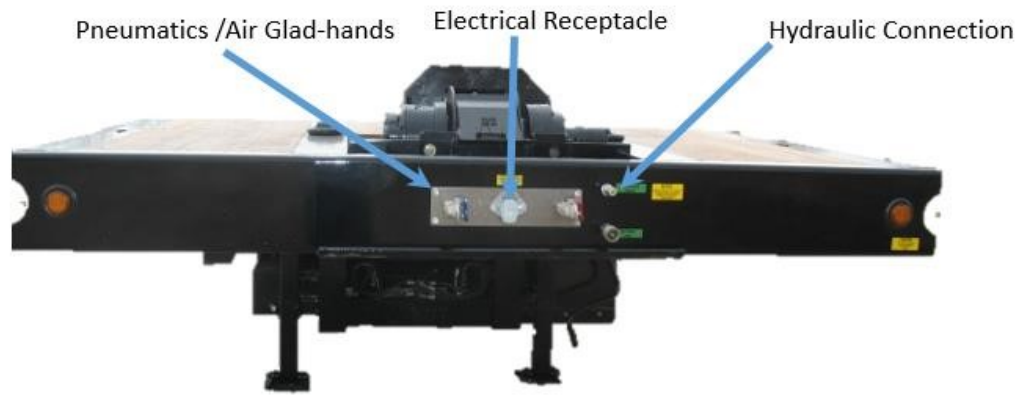

Front View of Trailer

- i) Climb into the cab and roll down the window and Conduct a tug test with the trailer parking brakes “still” engaged – the trailer should not move – ensure that you release the tractor parking brakes beforehand
- j) Activate air supply valve for the trailer from the tractor cab

**WARNING**

- k) Conduct a pre-trip inspection on the trailer
- l) Check brakes and lighting system for proper operation

### D.3. Disconnecting from Prime Mover

This segment describes the method to disconnect prime mover from the trailer.

- a) Disconnect the tractor supply and control brake hoses from the glad hands on the trailer. The trailer spring brakes will set automatically when the supply (emergency) air brake hose is uncoupled.
- b) Drain any water from the air reservoir by using the drain valve at the bottom of the air reservoir.
- c) Disconnect the electrical cable from the receptacle on the trailer.
- d) Disconnect hydraulic line.
- e) Lower the park stand style landing legs.
- f) Release the trailer kingpin from the tractors 5th wheel latch.
- g) Pull the tractor out from under the trailer, allowing the trailer to lower slowly until the park stand style landing leg shoes are firmly on the ground.

**NOTICE**

Please follow all safety precaution & have a clear area before operating the equipment

### D.4. Understanding Equipment Controls

Location of Controls on sliding axle trailer

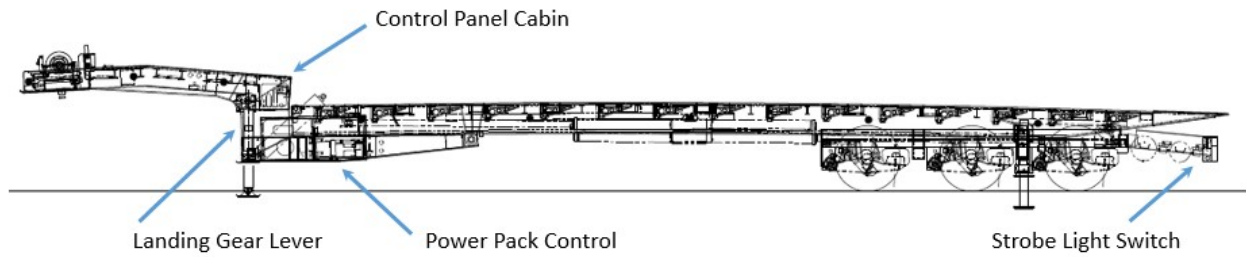

Switching on power pack engine

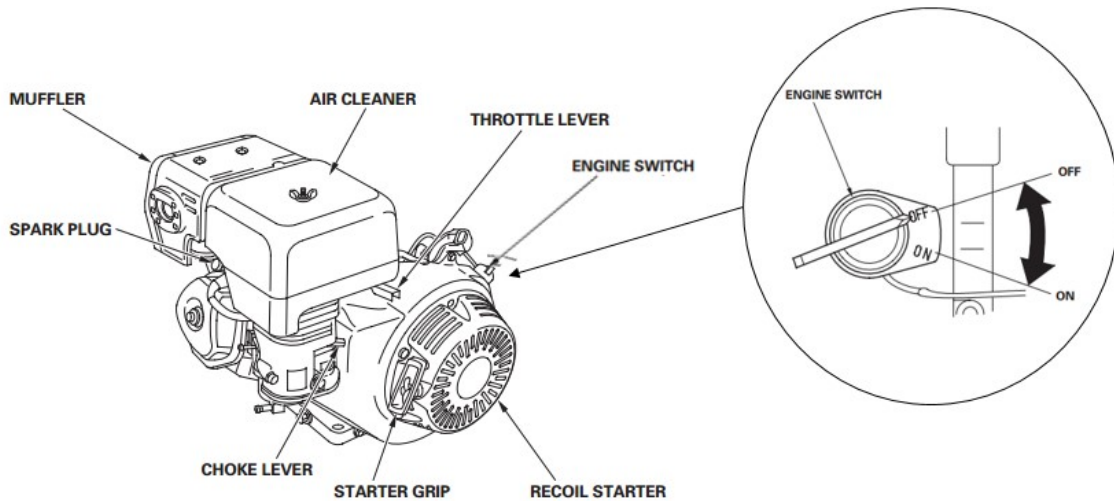

Main Control Panel is located on the road side of the trailer. This main control panel is used to operate deck tilting cylinders, slider cylinder, dock leveler legs, winch, air bags (dump / air), work lights and control cabin lights.



Remote Control Option – All the above said control can be controlled by a remote control pendant. This works with air – over – hydraulics set up. Connect the air supply to the trailer before using remote.



Strobe light switch is on the bumper of the slider (road side)



Rear Bumper View

Others: All other items are controlled from the tractor cab including Marker lights, Rear Trailer lights and Brakes

## D.5. Equipment Operations

### Before Loading or unloading the sliding axle trailer:

- Connect air & electrical to the trailer
- Connect pressure and return lines if using truck PTO
- If using power pack, switch on the power pack engine and engage the diverter valve to allow the power pack drive the hydraulics
- Set tractor brakes and release trailer brakes

**Loading the trailer:**

- a) Using appropriate lever from the control panel move the slider from travel position to front of trailer

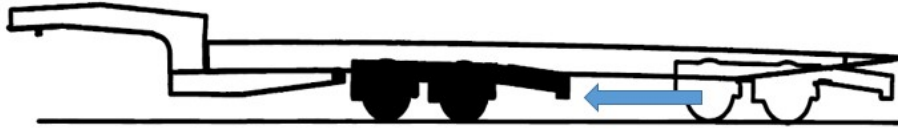

- b) Using appropriate lever tilt deck to the load angle required



- c) If using winch to load, unlock the winch spool using the control panel switch
- d) Hook up the winch and pull if necessary
- e) Position the load as far as possible on the deck & ensure the weight is distributed evenly on the trailer from side to side
- f) Move slider to rear of the trailer, adjust till the load's center of gravity is in front of the slider

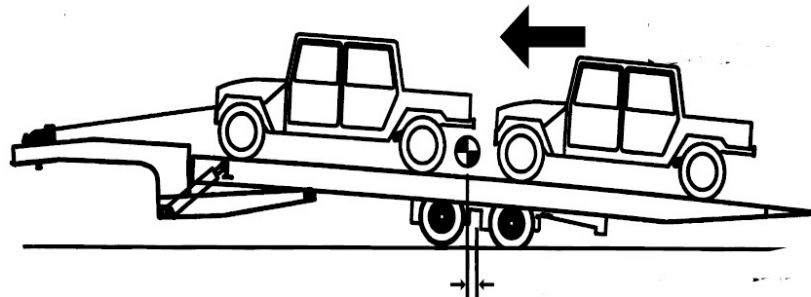

- g) Lower front deck and move the slider to the rear most position - the driving position

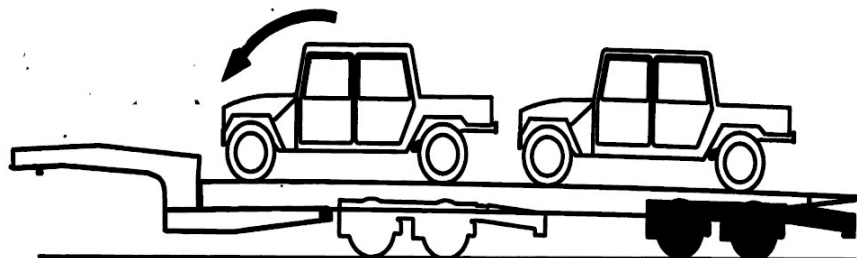

- h) Set trailer brakes, lock the winch spool & secure the load
- i) If trailer is equipped with dock levelers, make sure they are fully retracted
- j) Visually confirm the full retraction
- k) If using a power pack on trailer to operate – turn the power pack engine and fuel line off before travelling
- l) Note: Trailer should not be loaded to exceed GVWR and Should comply with local laws where the equipment is being used

**Unloading the trailer:**

- a) Ensure the load is secured to the trailer
- b) Using appropriate lever from the control panel move the slider from drive position to front of trailer until the load's center of gravity is slightly behind the axle



- c) Using the appropriate lever tilt the deck till the deck rests on the ground
- d) Move the slider to the front of the trailer

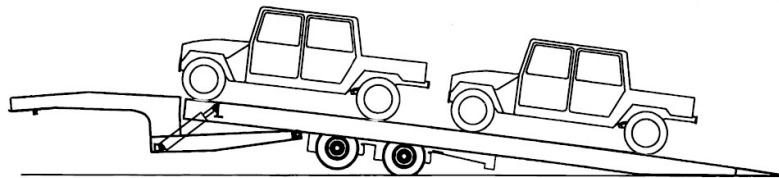

- e) Unload equipment
- f) Set trailer brakes, lock the winch spool & secure the load
- g) If trailer is equipped with dock levelers, make sure they are fully retracted, Visually confirm the full retraction
- h) If using a power pack on trailer to operate – turn the power pack engine and fuel line off before travelling

**Proper Driving Position of Slider on trailer:**

Move the slider to the rear most position while driving



## E. Preventative Maintenance

Preventative maintenance is maintenance that is regularly performed on a piece of equipment to lessen the likelihood of it failing. Preventative maintenance is performed while the equipment is still working, so that it does not break down unexpectedly. Lubrication and service performed at regular intervals will keep the Kalyn Siebert trailer in top operating condition for the longest period of time. The importance of regular inspection cannot be over-emphasized. Making necessary adjustments, tightening nuts and bolts, checking air lines, lights and wiring connections will help prevent serious trouble and delays on the road. The driver should be the first line of defense in Preventive Maintenance. A conscientious and alert operator will promptly report all need for adjustment or repair. A vehicle safety check should be performed daily prior to operation.

The driver is the first line of defense in Preventive Maintenance. A conscientious and alert operator will promptly report all need for adjustment or repair. Equipment safety check should be performed daily prior to operation. Preventative maintenance along with proper operation of the trailer will ensure low cost of ownership of Kalyn Siebert Equipment.

### E.1. Lubrication

Use recommended lubrication based on the application. It is not the policy of the Kalyn Siebert to guarantee lubricant performance. The responsibility for the quality of any lubricant rests solely with the distributor or manufacturer of the lubricant.

Lube Chart

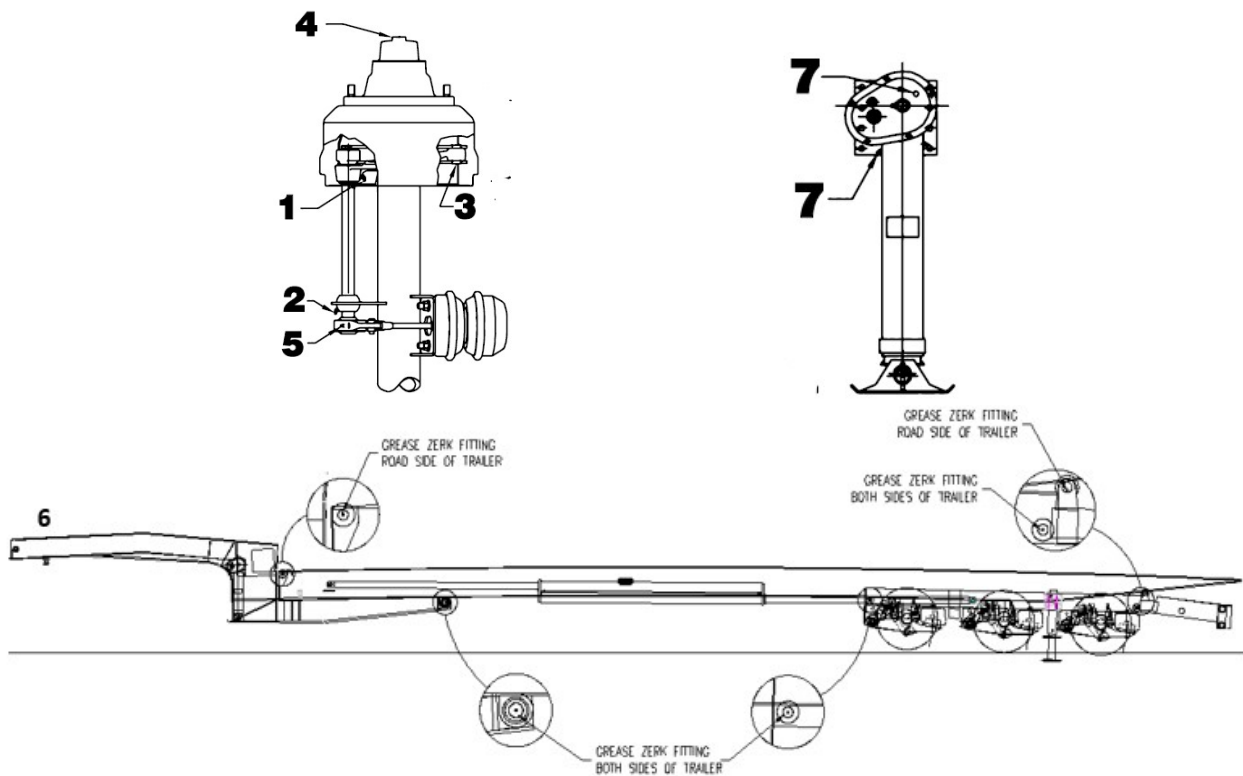

| Item | Lubrication Interval | Trailer Part              | Lubrication Requirement                 |
|------|----------------------|---------------------------|---|
| 1    | Every 2000 miles     | Brake cam shaft bearing   | E.P.I Chassis grease<br>N.L.G.I Grade 1 |
| 2    | Every 2000 miles     | Cam Shaft Bearing bracket | E.P.I Chassis grease<br>N.L.G.I Grade 1 |
| 3    | Every 2000 miles     | Brake shoe anchor pins    | E.P.I Chassis grease<br>N.L.G.I Grade 1 |
| 4    | Every 25,000 miles   | Wheel Bearing             | OIL SAE 85W-140<br>A.P.I Service GL-5   |
| 5    | Every 25,000 miles   | Slack Adjusters           | E.P.I Chassis grease<br>N.L.G.I Grade 1 |
| 6    | Every Month          | Rollers                   | E.P.I Chassis grease<br>N.L.G.I Grade 1 |
| 7    | Every 6 Months       | Landing Gear              | E.P.I Chassis grease<br>N.L.G.I Grade 1 |

## E.2. Tires & Wheels

Inspect tires and wheels daily for proper torque, inflation and even wear of tread.

### E.2.1 Wheel Bearing Adjustment

Bearing adjustment should be 0.001”-0.005” end play and a minimum of pre-load. Use the following procedure:

- Tighten inner jam nut with a 12 inch wrench while turning wheel in both directions until there is a slight bind which indicates all bearing surfaces are in contact.
- Back off inner jam nut 1/3 turn to allow the wheel to rotate freely.
- Install washer and tighten outer jam nut.
- Final bearing adjustment should be with 0.001” to 0.005” end play. Tighten nuts at this position.

Be extremely careful when working with tires and wheels. Tires & wheels can come apart with explosive force. Never attempt to disassemble a wheel with an inflated tire mounted on it.

## E.3. Brakes

The wheel brakes are equipped with slack adjusters for easy brake adjustment to compensate for brake lining wear. It is recommended that slack adjuster arm travel be held to a minimum for most efficient braking action. The brakes should be adjusted when total arm travel reaches 1-1/2”. To adjust brakes, depress lock sleeve on slack adjuster, then turn adjustment screw as required. Make sure lock sleeve returns to lock position when adjustment is complete. Every 5000 miles, the brake camshafts should be lubricated with approved chassis lubricant. Every 10,000 to 25,000 miles, the brakes should be serviced as follows:

- a) Remove wheels and hubs.

- b) Inspect brake roller shafts, cam rollers, anchor pins, camshaft support bushings spider bushings and camshaft for wear and replace if necessary. Lubricate these parts with chassis lubricant upon reassembly.
- c) Inspect brake linings for wear, loose rivets and any signs of grease on the braking surface. Oil-soaked linings are not reusable and must be replaced. Check to ensure that the linings have not worn to the point that rivet heads are contacting inside surface of drum. Reline or replace brake shoes if necessary.
- d) Check inside surface of drum. Rebooting of drums is not recommended, as the strength of refaced drums is greatly reduced. If drum is worn, replace it.
- e) Service the wheel bearings and seals if required. Reassemble hubs and wheels.

#### E.4. Torque Requirements

Tighten all bolts on trailer periodically with the following schedule

- f) First 5 days of service
- g) First 30 days of service
- h) First 60 days of service
- i) Every 90 days thereafter

Torque requirements for clean lubricated bolt threads only

**SAE Grade 5**

|  |                       |        |         |        |         |
|--|-----------------------|--------|---------|--------|---------|
|  | <b>Bolt Size (in)</b> | 1/4-20 | 5/16-18 | 3/8-16 | 7/16-14 |
|  | <b>Torque (ft-lb)</b> | 6.3    | 13      | 23     | 35      |

**SAE Grade 8**

|   |                       |        |        |        |       |     |         |
|---|-----------------------|--------|--------|--------|-------|-----|---------|
|  | <b>Bolt Size (in)</b> | 1/2-13 | 5/8-11 | 3/4-10 | 7/8-9 | 1-8 | 1.25-7t |
|   | <b>Torque (ft-lb)</b> | 80     | 160    | 280    | 450   | 680 | 1480    |

The above values do not apply to air or hydraulic fittings.

#### E.5. Axle Alignment

Properly aligned trailer axles optimize fuel economy, drive ability and help prevent excessive tire wear. Single Point Suspension Alignment Procedure is described here.

- a) Before measuring axle alignment, unload the trailer and free the suspension of any “binds” by pushing the trailer backwards and then pulling the trailer forward. While pulling the trailer forward on a level floor, apply the brakes and release. This will assure that the adjustable undercarriage is in its rearmost locked position. Trailers with air ride suspensions should be aligned with the suspension at its nominal ride height. The trailer **MUST** be level from side to side as well as from front to rear.
- b) Neither service nor parking brakes should be applied during the measurement procedure



- c) Use axle end extenders (or remove the outer wheels and any obstructions) to achieve a straight line for measuring from the king pin to the axle ends.
- d) You will need the following tools for proper axle alignment inspection:
  - Spring loaded, kingpin extender with bubble level
  - Axle end extenders
  - 50 ft. steel tape
  - Adjustable tram
  - Gauge for measuring axle center to axle center
- e) Measure distances A and B from the king pin to the front axle. Refer to Figure A. These must be equal within 1/8 inch of each other. Measure distances C and D between axles using the gauge as shown. Note that trailer axles have dimples or recesses at the center of the axle spindle ends; these also must be equal within 1/16 inch of each other. Determine the lateral centerline of the trailer body and axles. Distance E should not exceed 1/4 inch for either axle. (Distance E is the distance between axle and trailer centerlines.)

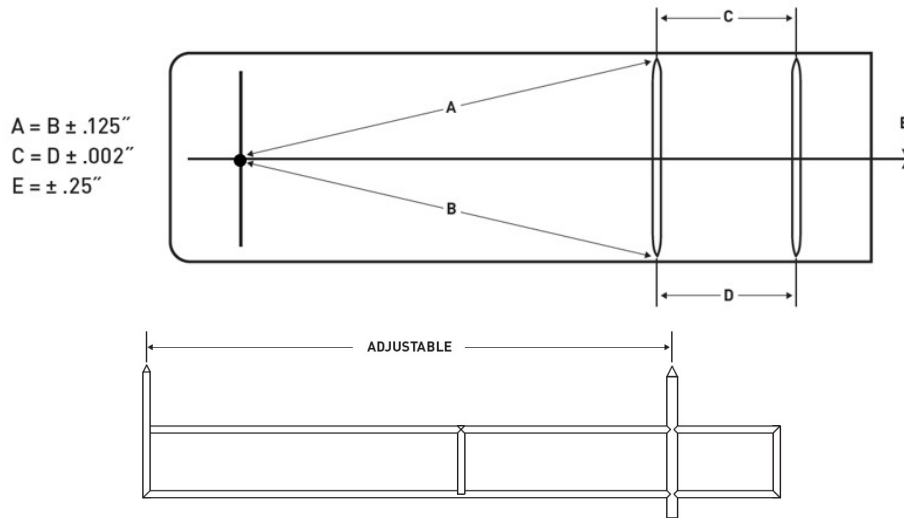

- f) Be sure to:
  - Always measure to the front axle ends for accurate alignment.
  - Avoid measuring to the rims, suspension brackets, hub cap vent holes, brake drums, etc. This can result in improper alignment.
  - Check and repair or replace problem suspension parts if you have trouble obtaining true alignment.
  - Always align any succeeding axles with the front axles, not the kingpin.

## E.6. Preventative Maintenance Schedule

Trailer should be inspected to insure it meets D.O.T. requirements. Refer to D.O.T. Transportation of Hazardous Materials Handbook (paragraph 177.824) if hazardous materials are to be hauled.

Use the following schedule to handle preventative maintenance work on the Kalyn Siebert trailers.

| Daily                        |  |
|------------------------------|--|
| Anti-Lock Brake System       | Check for proper operation   |
| Lights and Wiring            | Check all lights for proper operation  |
| All Bolts                    | Visually check for tightness   |
| Air Reservoirs               | Drain at the end of each shift   |
| Tires                        | Check for proper inflation and inflate   |
| Weekly                       |  |
| Wheel Seals                  | Check for oil leakage and oil level  |
| Wheel Lugs                   | Check for proper torque  |
| Wiring                       | Check all connections  |
| Suspension Bolts             | Check for proper torque  |
| Monthly                      |  |
| Supports                     | Lubricate; check mounting bolts for proper torque  |
| Axle Camshafts               | Lubricate all grease fittings  |
| Every 5,000 miles            |  |
| King Pin Alignment           | Check for proper alignment   |
| Brakes                       | Adjust as needed   |
| Wiring                       | Check for chafed or broken wires, ground wire connections, loose wire retaining clips and dielectric grease. |
| Upper 5th Wheel              | Lubricate  |
| Suspension                   | Check for proper bolt torque   |
| Every 10,000 TO 25,000 miles |  |
| Wheel Bearings               | Verify proper end play and adjust as necessary   |
| Brakes                       | Inspect linings, free-up brake shoes and anchor pins   |

**NOTE:** All the operation including preventative maintenance procedure on the Kalyn Siebert equipment should be done by trained personal.

**NOTE:** The above mentioned are part of basic preventative maintenance procedures and not the complete list of items that could be maintained on the Kalyn Siebert trailers.

## F. Parts of your Equipment

This segment of the manual shows the parts of a standard Kalyn Siebert Sliding axle trailer. For specific part to be reordered refer to the specification of the build since all the equipment built is customized and may have different parts associated. If parts are not mentioned on the specification sheet contact Kalyn Siebert Sales team to get assisted.

### Overall Curb Side View

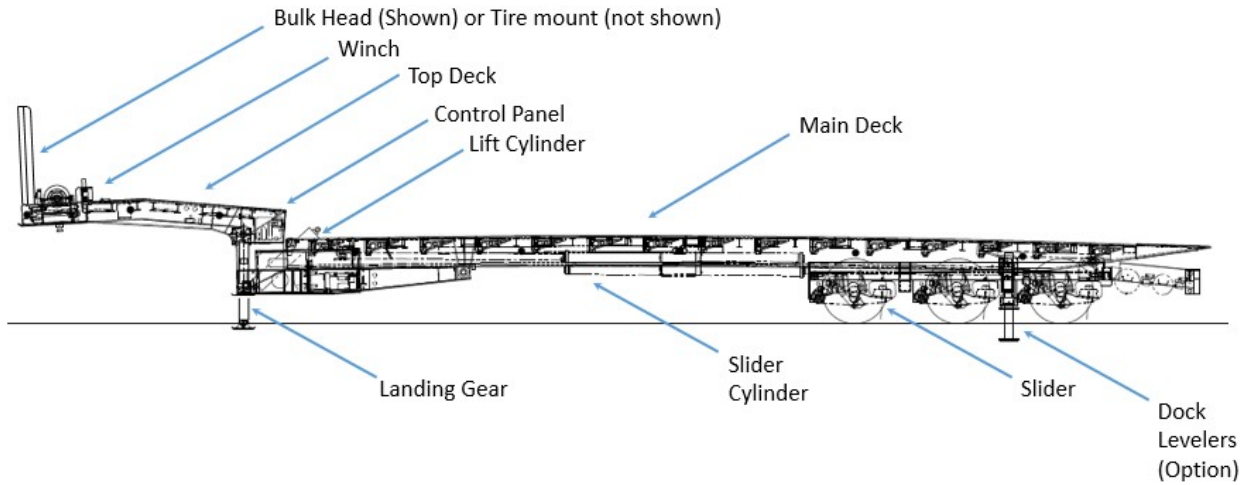

### Neck View

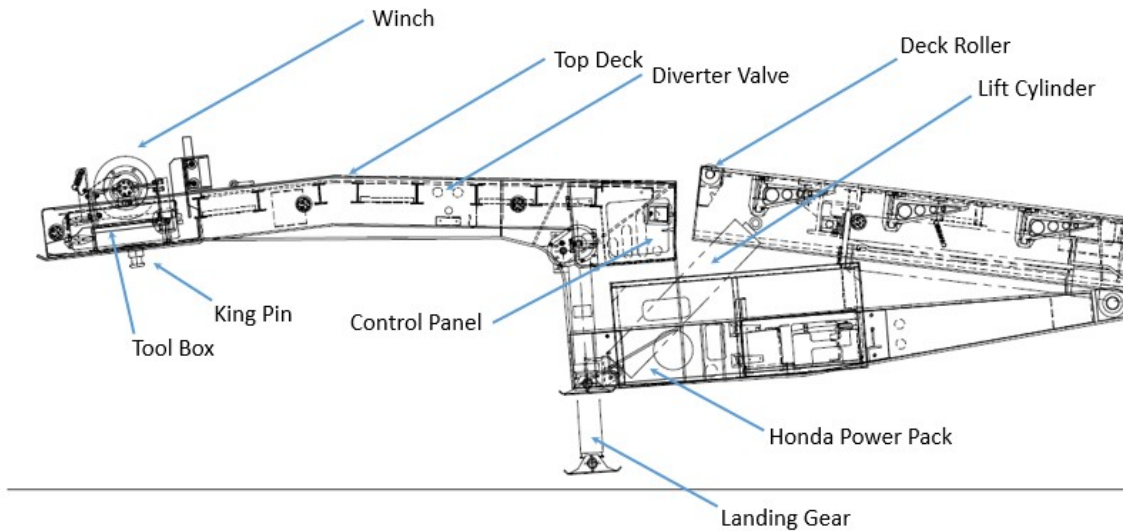

### Rear Bumper View

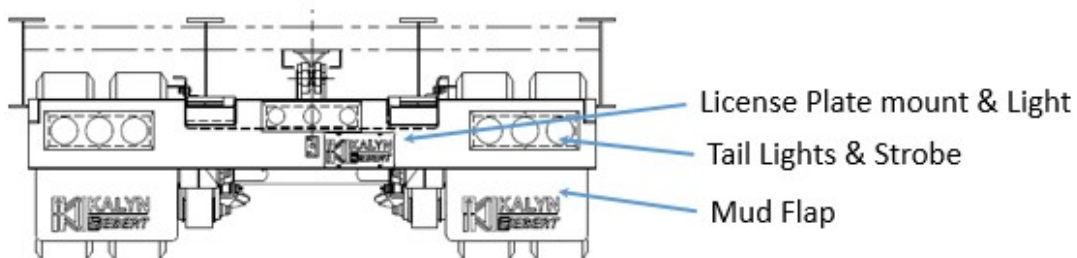

## Slider Assembly View

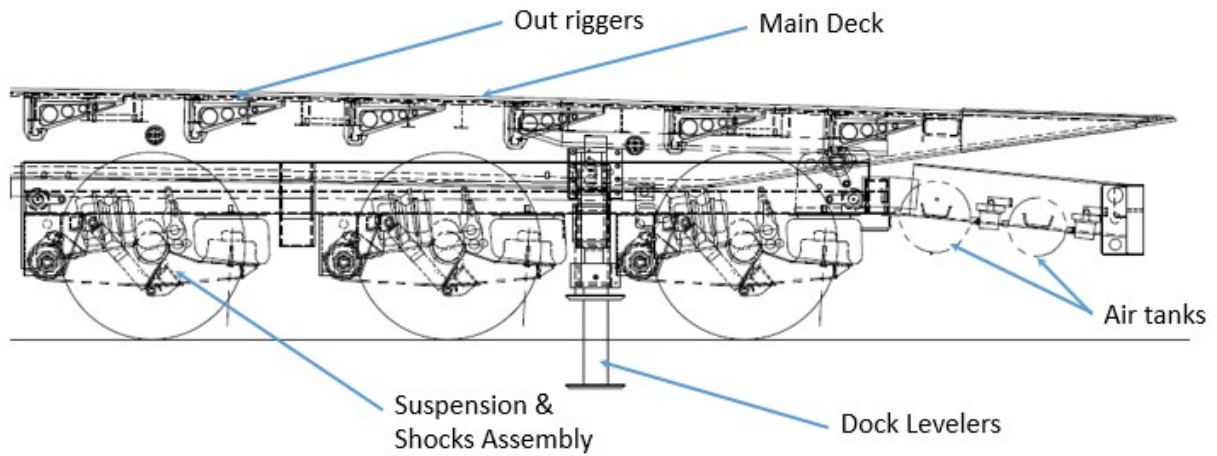

## Top View

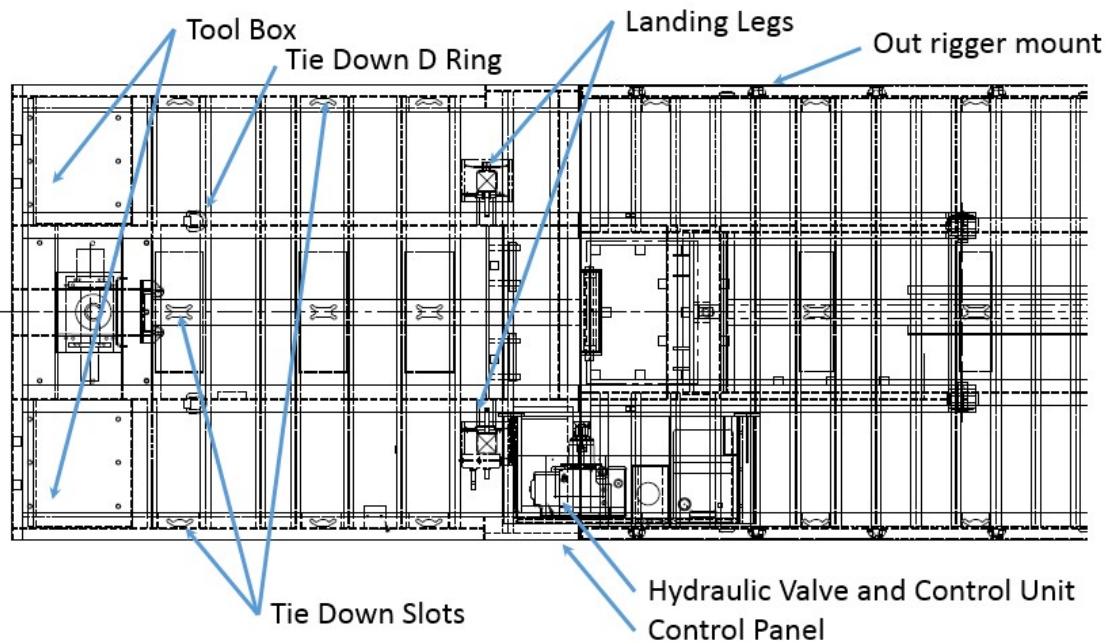
**F.1. Ordering Parts and Accessory equipment**

For ordering exact parts and accessory equipment to operate with your equipment please contact the parts team at Kalyn Siebert. Here is the contact information

Phone: 254-248-3340 or 254-248-3355

Email: [Commercial\\_Parts\\_Sales@kalyntx.com](mailto:Commercial_Parts_Sales@kalyntx.com)

Please use your equipment model name and VIN information from the data plate while ordering right parts.

## G. WARRANTY

The Kalyn Siebert Standard Warranty is included in this manual. In the unlikely event you need warranty service on your equipment purchased from Kalyn Siebert or its distributors, contact the distributor or Kalyn Siebert (1-254-865-7235, ext. 6234) directly, for service and repair procedures.

For all parts, claims or inquiries, refer to the model and serial number of your unit. This information is found on the equipment's data plate.

### G.1. LIMITED WARRANTY AGREEMENT

February 26, 2015

A copy of the warranty agreement is also available online at [www.kalynsiebert.com](http://www.kalynsiebert.com)

#### G.1.1. Warranty Limits

G.1.1.A. Kalyn Siebert, warrants its trailers to be free from defects in materials and workmanship under normal use, when proper service and maintenance as described in its Service Bulletins and Operation manuals are performed and with loads not exceeding the manufacturer's rated capacities, for a period of twelve (12) months from the date when these products are delivered to the first purchaser.

G.1.1.B. Kalyn Siebert's sole obligation under this warranty shall be limited to repair or replacement, at its option, of any defective part of the warranted equipment which is the result of defective material and/or workmanship of parts furnished by Kalyn Siebert which is returned to Kalyn Siebert or its designee round trip freight prepaid. Kalyn Siebert does not assume any liability for transportation charges, loss of profits, direct or indirect losses and consequential losses or any other damages or delays.

G.1.1.C. Any improper use, operation beyond rated capacity, substitution of parts not approved by us, or any alteration or repair by others in such manner, as in our sole judgment, affects the product materially and adversely, shall void this warranty.

G.1.1.D. Kalyn Siebert's warranty administrator, must authorize all labor and parts. Failure to get this authorization will result in no warranty payment of any kind.

#### G.1.2. Repair and/or Replacement Schedule

G.1.2.A. Main frame: Kalyn Siebert, shall bear that portion of the cost of repairing or replacing the main frame of the equipment found to be defective within a sixty (60) month warranty period on following schedule:

|                       |                      |
|-----------------------|----------------------|
| One (1) year – 100%   | Two (2) years – 80%  |
| Three (3) years – 70% | Four (4) years – 60% |
| Five (5) years – 50%  |                      |

G.1.2.B. Component parts and all other frame parts: Components manufactured by Kalyn/Siebert, shall be warranted for one (1) year.

Components manufactured by others and supplied by us will be subject to warranties, if any, of their respective manufacturers.

#### G.1.3. Procedure for Handling Warranty Repairs

G.1.3. A. The customer is responsible to contact Kalyn Siebert, warranty administrator with the following information:

- I. Trailer model and serial number
- II. Explanation of defects
- III. Any special circumstance that may exist.

The warranty administrator and the engineering staff, to determine if the claim is warrantable, will evaluate this information. After the claim is determined to be warrantable a warranty claim number will be assigned. No warranty claim or invoice will be processed for payment if it does not have a warranty claim number.

G.1.3. B. Warranty repair work is to be performed by Kalyn Siebert or their dealers, or qualified facilities recognized by Kalyn Siebert, (See exceptions at paragraph C). The customer and/or repair facility must provide the warranty administrator the following:

- I. Estimated cost of repair
- II. Pictures of the damaged area in need of repair
- III. All or any part of the defective materials, if requested by the warranty manager

G.1.3. C. Circumstances that preclude warranty repair work at facilities specified in paragraph B, such as overseas locations or others that make transporting the equipment to those locations difficult or impossible, will be handled by contacting the Kalyn Siebert warranty administrator. The warranty administrator will negotiate a resolution in one of the following manners:

- I. The owner of the trailer must contact Kalyn/Siebert with the nature of the problem.
- II. Authorization for repairs may be made using a local service facility or an on-site repair facility.
- III. Pictures and cost estimate must be sent to the warranty administrator for approval prior to work being performed.
- IV. In an emergency situation where repairs are made prior to authorization, a summary of repairs and cost must be submitted within (10) days to Kalyn/Siebert for evaluation and approval.

G.1.3. D. Kalyn Siebert, engineering staff must evaluate and issue repair instructions for any repairs that may affect the structural integrity of the trailers. Failure to do so may result in no warranty payment of any kind and the possibility of voiding the warranty on the trailer.

G.1.3.E. Kalyn Siebert, reserves the right to ship parts and/or materials required for the repairs or to authorize the procurement of parts and/or materials at the location of the repairs. Kalyn Siebert, will only reimburse parts and/or materials cost at Kalyn Siebert's approved price whether the work was done by Kalyn Siebert's authorized dealer or by an authorized repair facility.

G.1.3.F. In certain situations, the customer will be required to pay the repair facility for the repairs performed. In this situation, the customer will pay the invoices and, if requested by Kalyn Siebert, will have defective parts and/or materials have shipped to Kalyn Siebert, prepaid.

G.1.3.G. Under certain circumstances, Kalyn Siebert, will require trailers to be returned to the factory for proper evaluation and/or repairs. Transportation expenses to and from the factory will be borne by the customer.

#### G.1.4. Parts Retention and Parts Shipping

G.1.4.A. Customers or authorized dealers will be responsible to retain all defective parts and materials in which a warranty claim was submitted. All defective parts and materials will be held until one of the following situations occur:

- I. Kalyn/Siebert, requests the defective parts and materials be shipped to the factory for evaluation. At this time Kalyn/Siebert, will issue shipping instructions. All defective parts and material shipped to Kalyn/Siebert, must be prepaid by the customer and/or authorized repair facility.

Mailing Address:

Kalyn Siebert,  
P.O. Box 1078  
Gatesville, Texas 76528

Shipping Address:

Kalyn Siebert,  
1505 West Main Street  
Gatesville, Texas 76528

- II. Scrapping of defective parts and material after authorized by the Kalyn Siebert,

#### G.1.5. Reporting Warranty Claims

G.1.5.A. All warranty claims must be reported to the Kalyn/Siebert, warranty administrator within ten (10) days of discovery of defect. The attached Warranty Authorization Request Form must be completed and returned to the Kalyn Siebert, warranty administrator.

G.1.5.B. After Kalyn Siebert, issues a warranty claim number the repairs and/or replacement work must be scheduled within thirty (30) days thereafter. If repairs and/or replacement work is not scheduled in this time frame, Kalyn Siebert, reserves the right to re-evaluate the claim and the cost involved in the repairs.

G.1.5.C. To report a warranty claim, contact The Warranty Manger, Kalyn Siebert  
Bus main: 1-254-865-7235, ext. 6350  
FAX: 1-254-865-7234  
Business: 1-800-525-9689, ext. 6350

#### G.1.6. Reimbursement for Warranty Repairs

G.1.6.A. Kalyn Siebert, will reimburse labor cost at an approved rate per hour times the established Kalyn Siebert, flat rate time guide. If no flat rate is established, the actual time to perform the operation will be used.

G.1.6.B. Kalyn Siebert, will reimburse parts and materials at Kalyn Siebert's approved price whether the repairs were done by a Kalyn Siebert, authorized dealer or by an authorized repair facility.

G.1.6.C. All labor, parts, and material warranty claims must be authorized and have had prior approval by the Kalyn Siebert, warranty administrator. Failure to do so will result in no warranty payment of any kind.

G.1.6.D. Warranty claims will be processed and paid once a month by check.

G.1.6.E. Kalyn Siebert, warrants that this trailer is manufactured in accordance with the specifications on the order

G.1.6.F. Kalyn Siebert accepts no responsibility for damage to the equipment, or for cargo losses, due to an adverse effect on the equipment caused by the incompatibility of the product being hauled on the trailer. Kalyn Siebert makes no warranty of products manufactured and/or installed by others, the same being subject to warranties, if any, of their respective manufactures or installers. The customer shall bear the risk for damage or loss to the trailer or injury to property or person.

#### G.1.7. Parts Shipment

G.1.7.A. Kalyn Siebert, is able to ship parts and materials anywhere in the United States with an overnight service depending on the following:

- I. The availability of the parts.
- II. The weight and size of the shipment meets UPS criteria.
- III. The request is placed early enough in the day so the shipment can be packaged, invoiced, and shipped.

#### G.1.8. Appeals

Any appeals negotiated between the customer and Kalyn Siebert, warranty administrator that cannot be resolved by telephone will have to be negotiated at Kalyn Siebert, L.P. in Gatesville, Texas.



G.1.9. Validating the Kalyn Siebert, Trailer Warranty

G.1.9.A. In order to validate your Kalyn/Siebert, trailer warranty, the attached warranty registration must be signed by the owner and returned to Kalyn/Siebert, by the owner.

G.1.9.B. Signing the owners warranty registration acknowledges that the owner has received the owner's manual and a copy of the manufacturer's warranty policy and has read and understands the operation and proper maintenance of the vehicle.

G.1.9.C. Online registration is also available at [www.kalynsiebert.com](http://www.kalynsiebert.com)

G.1.10. Point of Contact

G.1.10.A. Kalyn/Siebert, Warranty Manager

1-800-525-9689, ext. 6350

1-254-865-7235, ext. 6350

1-254-865-7234, fax

The above warranty supersedes and is in lieu of all other warranties expressed or implied.

## G.2. COPY OF EQUIPMENT REGISTRATION FORM

Please fill all the fields on equipment registration form shown here. The form is available online or with the product manual. Any information collected from our users will not be sold, shared, or rented to others.

Kalyn Siebert Equipment – Warranty Registration Form

### KALYN SIEBERT – WARRANTY REGISTRATION FORM

\*Unless otherwise noted, all fields are required

**TRAILER INFORMATION:**

Trailer Serial Number (Full VIN#): \_\_\_\_\_

In Service Date: \_\_\_\_\_

**OWNER INFORMATION:**

Company Name: \_\_\_\_\_

Contact Name: \_\_\_\_\_

Address 1: \_\_\_\_\_

Address 2: \_\_\_\_\_

City: \_\_\_\_\_ State: \_\_\_\_\_ Zip: \_\_\_\_\_

Phone Numbers: Bus: \_\_\_\_\_ Cell: \_\_\_\_\_

Fax: \_\_\_\_\_ Email: \_\_\_\_\_

Alternate Email (If Available): \_\_\_\_\_

**DEALER INFORMATION:**

Dealer Name: \_\_\_\_\_

Address 1: \_\_\_\_\_

Address 2: \_\_\_\_\_

City: \_\_\_\_\_ State: \_\_\_\_\_ Zip: \_\_\_\_\_

Phone Numbers: Bus: \_\_\_\_\_ Cell: \_\_\_\_\_

Fax: \_\_\_\_\_ Email: \_\_\_\_\_

Alternate Email (If Available): \_\_\_\_\_

Please send this form to us through one of the following methods:

**FAX NUMBER:** 254 885 7234

**EMAIL ADDRESS:** forandall@kalyntx.com

**POSTAL ADDRESS:** 1505 W MAIN, GATESVILLE, TEXAS – 76528

Kalyn Siebert

**Kalyn Siebert - 1505 W. Main St., Gatesville, TX 76528**  
**kalynsiebert.com - General\_Inquiry@kalyntx.com**  
**(254) 865-7235**

**ENGINEERED TO PERFORM. BUILT TO LAST.**